

Current Transducer LTC 600-S

$I_{PN} = 500 \text{ A}$

For the electronic measurement of currents : DC, AC, pulsed..., with a galvanic isolation between the primary circuit (high power) and the secondary circuit (electronic circuit).

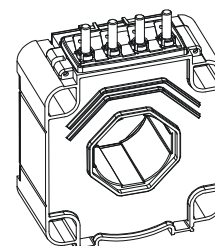

Electrical data

I_{PN}	Primary nominal r.m.s. current	500	A			
I_P	Primary current, measuring range @ 24 V	0 .. ± 1500	A			
\hat{I}_P	Max overload not measurable	10 / 10	kA/ms			
R_M	Measuring resistance	R_{Mmin}	R_{Mmax}			
				with ± 15 V	@ ± 500 A _{max}	0
			@ ± 1200 A _{max}	0	5	Ω
		with ± 24 V	@ ± 500 A _{max}	0	150	Ω
	@ ± 1500 A _{max}	0	20	Ω		
I_{SN}	Secondary nominal r.m.s. current	100	mA			
K_N	Conversion ratio	1 : 5000				
V_C	Supply voltage (± 5 %)	± 15 .. 24	V			
I_C	Current consumption	< 30 (@±24V) + I_S	mA			

Features

- Closed loop (compensated) current transducer using the Hall effect
- Insulated plastic case recognized according to UL 94-V0
- Railway equipment.

Advantages

- Excellent accuracy
- Very good linearity
- Low temperature drift
- Optimized response time
- Wide frequency bandwidth
- No insertion losses
- High immunity to external interference
- Current overload capability.

Accuracy - Dynamic performance data

X_G	Overall accuracy @ I_{PN} , $T_A = 25^\circ\text{C}$	< ± 0.7	%
		@ I_{PN} , $T_A = -40^\circ\text{C} .. +85^\circ\text{C}$	< ± 1.6
e_L	Linearity	< 0.1	%
		Max	
I_O	Offset current @ $I_P = 0$, $T_A = 25^\circ\text{C}$	± 0.5	mA
I_{OT}	Thermal drift of I_O - 40°C .. + 85°C	± 1	mA
t_r	Response time ¹⁾ @ 90 % of I_{PN}	< 1	μs
di/dt	di/dt accurately followed	> 100	A/μs
f	Frequency bandwidth (- 1 dB)	DC .. 100	kHz

Applications

- AC variable speed drives and servo motor drives
- Static converters for DC motor drives
- Battery supplied applications
- Uninterruptible Power Supplies (UPS)
- Switched Mode Power Supplies (SMPS)
- Power supplies for welding applications.

General data

T_A	Ambient operating temperature	- 40 .. + 85	°C
T_S	Ambient storage temperature	- 45 .. + 90	°C
R_S	Secondary coil resistance @ $T_A = 85^\circ\text{C}$	44	Ω
m	Mass	750	g
	Standards	EN 50155 : 2001	

Application Domain

- Traction

Note: ¹⁾ With a di/dt of 100 A/μs.

Current Transducer LTC 600-S

Isolation characteristics

V_d	R.m.s. voltage for AC isolation test, 50 Hz, 1 mn	13.4 ²⁾	kV
		1.5 ³⁾	kV
V_e	R.m.s. voltage for partial discharge extinction	> 2.8	kV
		Min	
dCp	Creepage distance	66.70	mm
dCl	Clearance distance	45.90	mm
CTI	Comparative Tracking Index (Group I)	600	

Notes : ²⁾ Between primary and secondary + shield

³⁾ Between secondary and shield.

Safety



This transducer must be used in electric/electronic equipment with respect to applicable standards and safety requirements in accordance with the following manufacturer's operating instructions.



Caution, risk of electrical shock

When operating the transducer, certain parts of the module can carry hazardous voltage (eg. primary busbar, power supply).

Ignoring this warning can lead to injury and/or cause serious damage.

This transducer is a built-in device, whose conducting parts must be inaccessible after installation.

A protective housing or additional shield could be used.

Main supply must be able to be disconnected.

Dimensions LTC 600-S (in mm. 1 mm = 0.0394 inch)

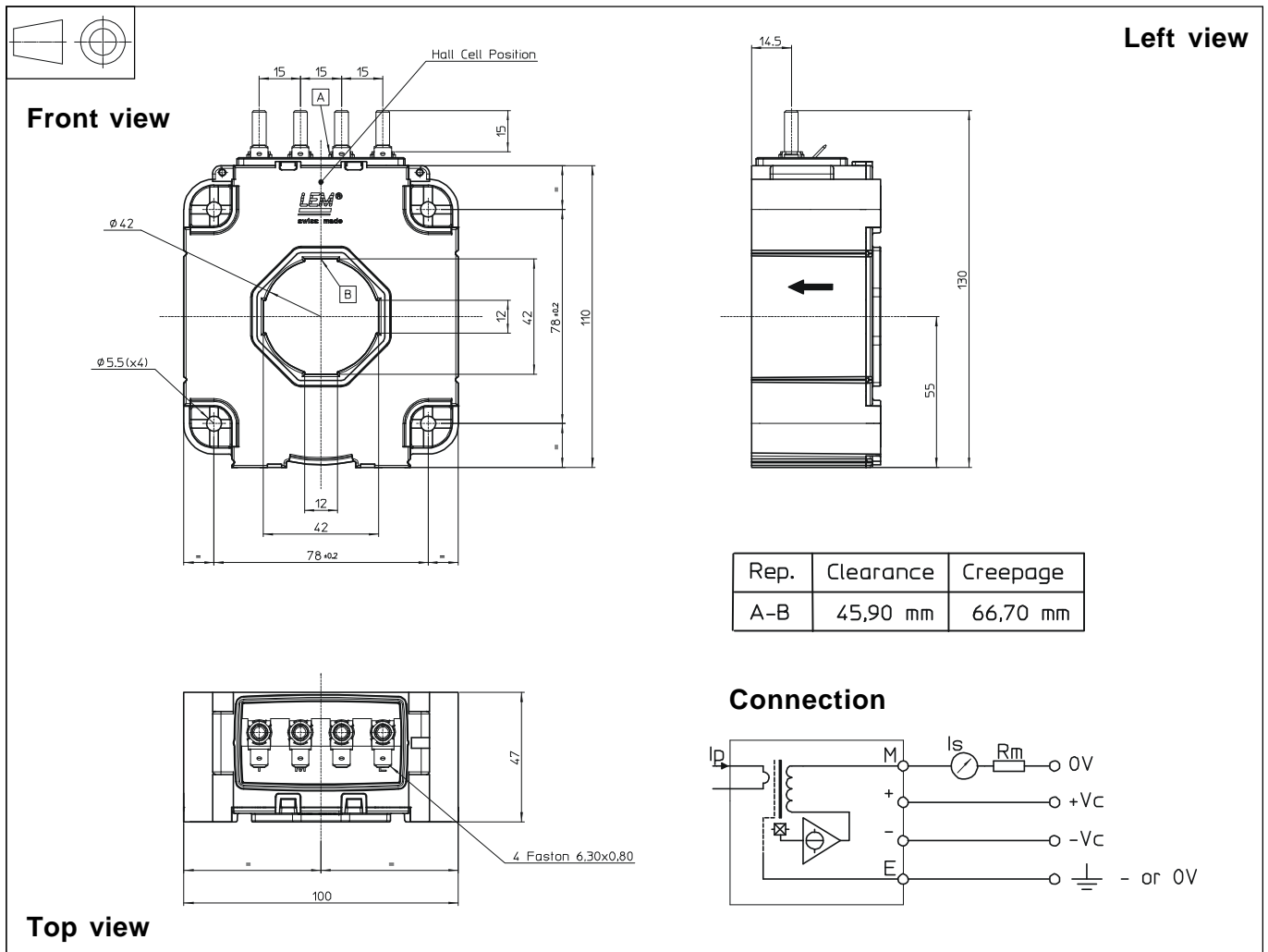

Mechanical characteristics

- General tolerance ± 1 mm
- Fixing the transducer
 - 4 holes $\varnothing 5.5$ mm
 - 4 screws M5
- Fastening torque max 3.7 Nm
- Primary through-hole $\varnothing 42$ mm
- Connection of secondary
 - M5 threaded studs
 - Fastening torque max 2.2 Nm or 1.62 Lb.-Ft.
 - Faston 6.3 x 0.8 mm

Remarks

- I_s is positive when I_p flows in the direction of the arrow.
- Temperature of the primary conductor should not exceed 100°C .
- Dynamic performances (di/dt and response time) are best with a single bar completely filling the primary hole.
- This is a standard model. For different versions (supply voltages, turns ratios, unidirectional measurements...), please contact us.

LTC 600-S / Mechanical adaptation accessories

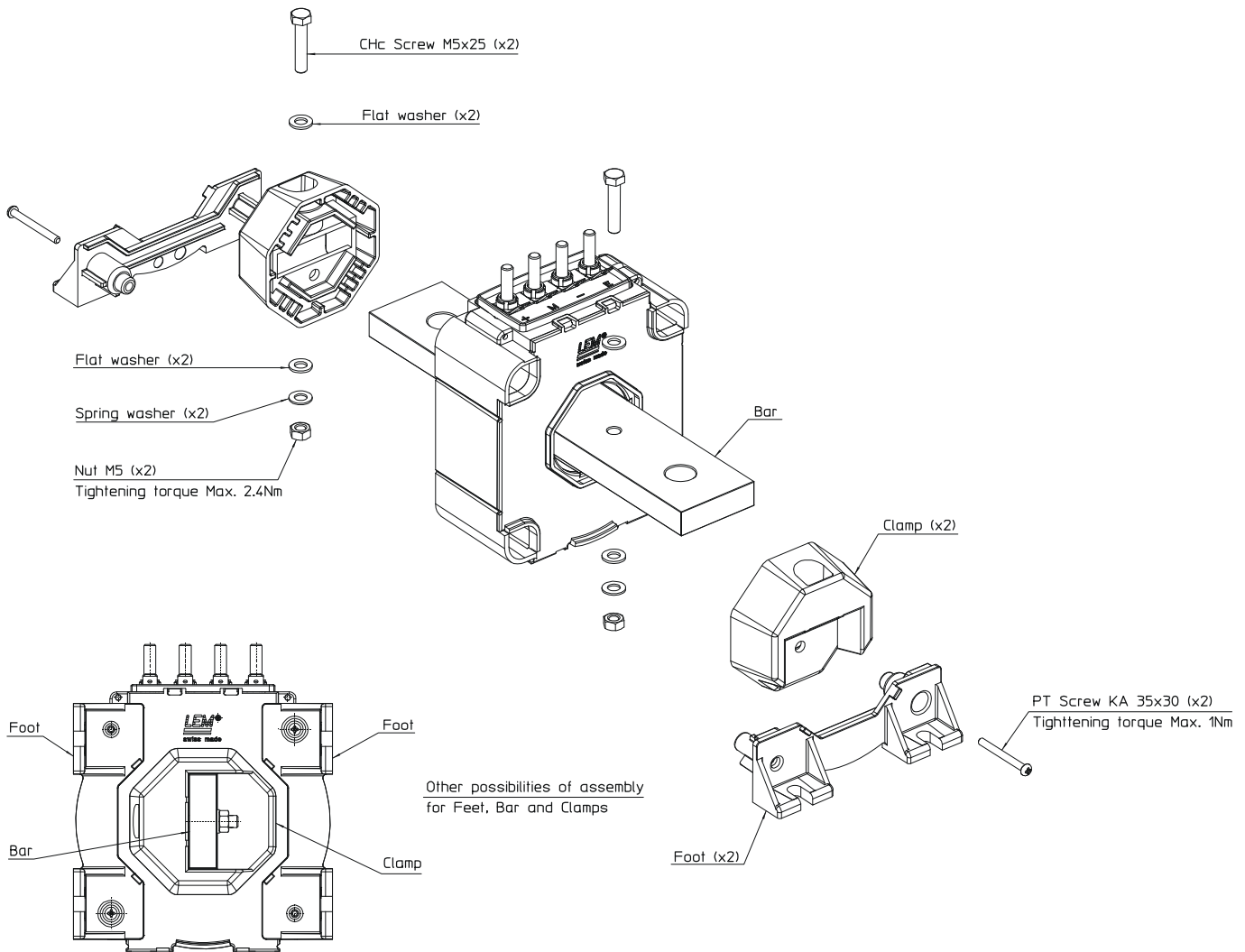

Line	Accessories	References
1	Busbar KIT* (busbar : 210 x 40 x 12 mm)	93.34.61.100.0
2	Busbar KIT* (busbar : 185 x 40 x 8 mm)	93.34.61.102.0
3	Busbar KIT* (busbar : 285 x 36 x 12 mm)	93.34.61.103.0
4	Busbar KIT* (busbar : 260 x 36 x 12 mm)	93.34.61.104.0
5	Busbar KIT* (busbar : 195 x 36 x 10 mm)	93.34.61.105.0
6	Busbar KIT* (busbar : 36 mm Ø x 325 mm)	93.34.61.106.0
7	Busbar KIT* (busbar : 185 x 40 x 10 mm)	93.34.61.107.0
8	Busbar KIT* (busbar : 180 x 40 x 12 mm)	93.34.61.108.0
9	Busbar Fastening Kit (M5 x 25)**dedicated to busbars from lines 1 to 5 and lines 7, 8	93.34.61.200.0
10	Busbar Fastening Kit (M5 X 40)** dedicated to busbar from line 6	93.34.61.201.0
11	Feet fixing Kit ***	93.34.63.100.0

* including all the necessary for its mounting such as screws, washers, nuts, 2 clamps, busbar.

** as with * but without the busbar.

*** including screws and 2 feet.



R.m.s. voltage value for partial discharge extinction depends on the busbar. Refer to the datasheet of the corresponding product.